

ME 2000 USER MANUAL

ACCESSORY/STRUCTURE

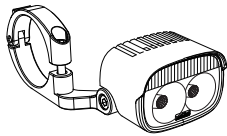

ME 2000



3mm Hex

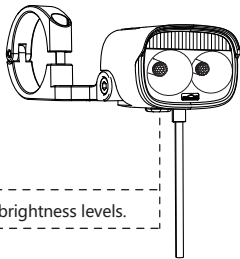

Button and light sensor

Button: For choosing the modes and brightness levels.

Light perception:

Smart light sensor will judge whether open the main light according to the light environment. Only the DRL will be turned on during the daytime once power on.

- Notice:
- The light needs to match power with the new e-bike before first using to reach the maximum light effect.
 - The light defaults to the minimum power state from the factory setting.
- ▲ Instructions of power matching :
1. Long press the button on the bottom of the light(Under power off situation)
 2. Power on the E-bike
 3. Wait the light working from min brightness to max brightness to turn off.
 4. Power match successfully,power on the E-bike again.

HOW TO INSTALL

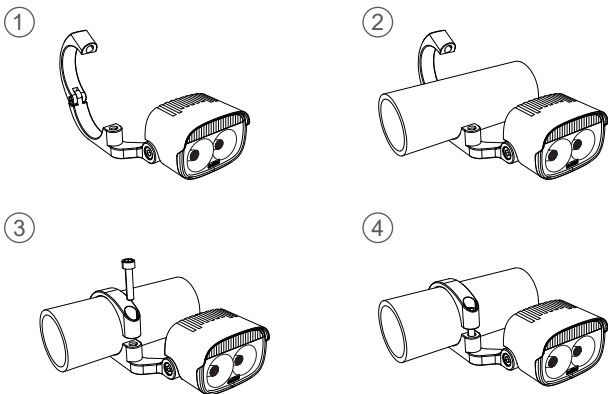

INTELLIGENT OPERATION

Mode memory : The light resumes previous mode upon next usage.

The brightness sensor is activated by default, it automatically switches between day time running light and steady/flash mode.

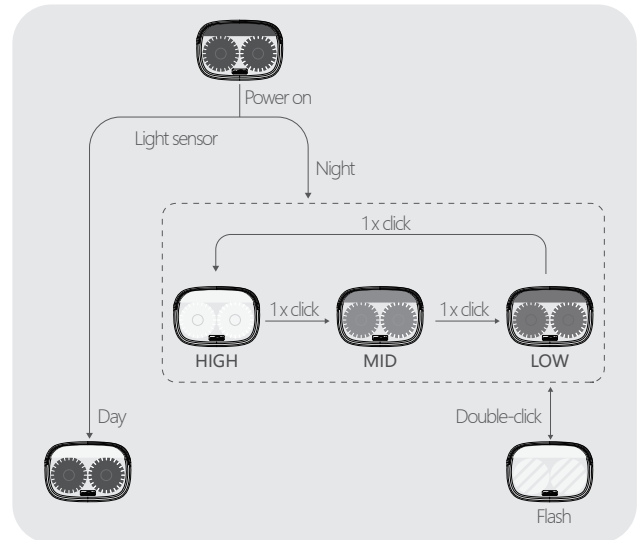

Notice: The light will remember and keep the same brightness as last using setting when restart.

MODE AND BRIGHTNESS

	MODE	BRIGHTNESS		MAX LUMENS
 NIGHTTIME	STEADY	HIGH	100%	2000
		MID	50%	1000
		LOW	30%	600
	FLASH	/	30%	600
 DAYTIME	DRL	DAYTIME RUNNING LIGHTS ARE ALWAYS ON		20

The light can judge the maximum brightness automatically according to the output power of the motor interface

MOTOR OUTPUT (W)	HIGH(LM)	MID(LM)	LOW(LM)
3W	300	150	80
6W	750	350	170
7.2W	880	400	200
9W	1100	550	260
18W	1800	900	450
24W	2000	1000	600

▲ The data above is only for reference.

⚠ WARNING



EN WARRANTY

The Magicshine lighting system is warrantied for 24 months from the date of purchase.

If you register the lighting system on the Magicshine website you will receive a bonus 6 month warranty.

Battery packs and AC adapters have a 6 month warranty, however, there is no bonus warranty available.

The warranty is limited to defects in material and workmanship on the lighting system itself, the battery pack and the AC adapter.

The warranty is only valid if the affected parts have not been tampered with and there is no intentional damage. Please keep your proof of purchase in a safe place. Proof of purchase must be presented in the event of any claim. Please contact the specialist retailer from whom you purchased the device for complaint or warranty claim.

Alternatively, you can send your complaint or claim directly to Magicshine at

Tel: (+86) 755-295 536 69

Fax: (+86)755-275 897 77

E-mail: support@magicshine.com (order from Magicshine.com online store)

service@magicshine.com (order from other sales channels)

In the event of a justified warranty claim and delivery of a replacement device, you will only be entitled to a model available when replacing. The manufacturer retains the right to make technical modifications.

ANSI FL 1 STANDARD

